

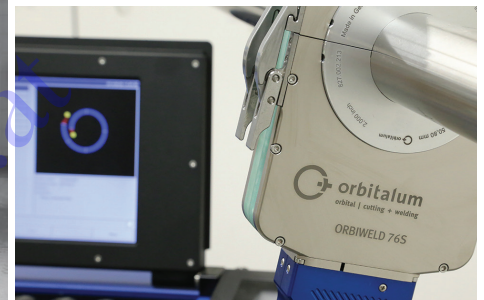

ORBIWELD 38S, 76S, 115S

Enclosed orbital weld heads

Easier to handle, more economical, more effective - enclosed TIG orbital welding heads with outstanding characteristics: The ORBIWELD "S" series from Orbitalum convinces by its extremely narrow design and high durability by its efficient integrated water cooling system.

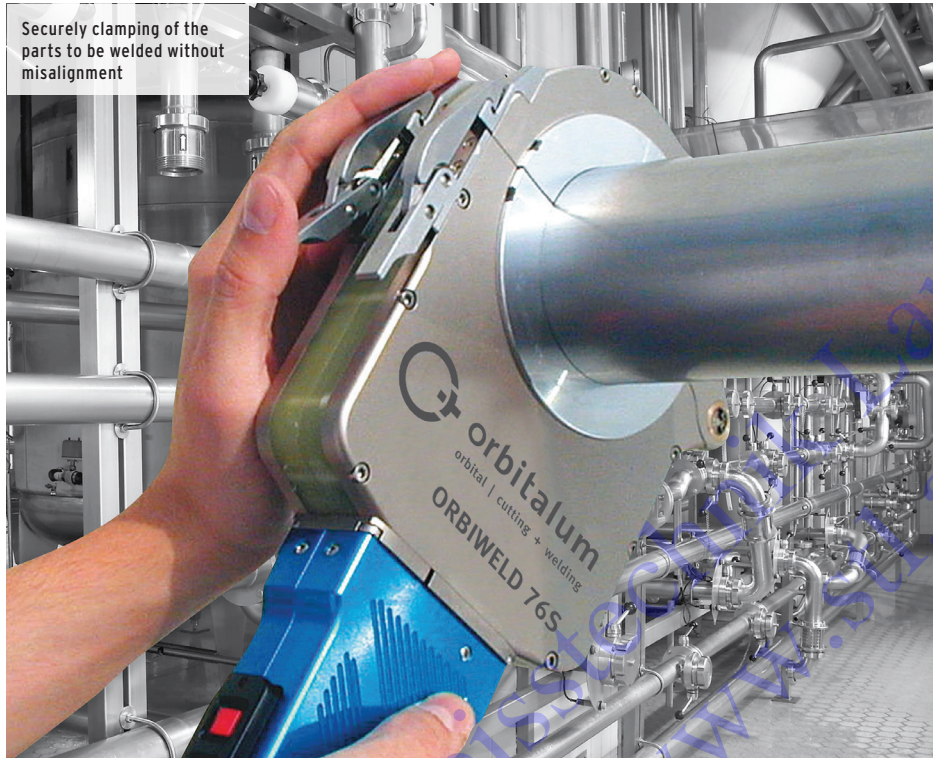

In combination with a power source of the ORBIMAT CA series a welding system with maximum precision

The small dimensions of the ORBIWELD "S" series make it ideal for applications where space is very restricted, such as the pharmaceutical and chemical industry, the semiconductor, food and beverage industry as well as aerospace.

All enclosed orbital weld heads of the ORBIWELD series are made from strong, durable materials of the finest quality and are characterised by their unique water cooling system.

The appropriate high-grade, functional and long-lasting clamping inserts are lasting longer than the inserts of many competitors. The inserts are available in small and wide design and easily and quickly insertable into the weld heads.

ADDITIONAL FEATURES:

- Thanks to the extremely narrow design, parts with short straight welding lengths can also be processed
- High-quality, rugged housing and handle parts
- High durability due to completely water-cooled weld head housing
- Highly flexible hose package (Length: 7.5 m/ 24.6 ft) with strain relief to the power supply
- All the important commands for welding can be transmitted to the power supply via a control panel built into the robust and durable aluminum handle, so that no additional remote control is required
- Quick change system for clamping inserts that engages and releases smoothly without any tools

- Cost-effective clamping inserts
- Durable clamping connections in combination with clamping inserts available for all tube dimensions guarantee that the parts to be welded are clamped securely without misalignment
- Comprehensive and customer-specific range of accessories
- NEW: A folding cover at the weld head enables to test and/or to readjust the electrode position before the welding procedure

APPLICATION RANGE	ORBIWELD 38S	ORBIWELD 76S	ORBIWELD 115S
Code	826 000 001	827 000 001	828 000 001
Tube OD, min. - max.	3 - 38.1 mm 1/8" - 1.5"	6 - 77 mm 1/4" - 3.0"	20 - 115 mm 3/4" - 4.5"
Electrode Ø	1.6/2.4 mm .063"/.094"	1.6/2.4 mm .063"/.094"	1.6/2.4 mm .063"/.094"
Weight	9 kg 19.8 lbs	9.4 kg 20.7 lbs	13 kg 28.7 lbs
Hose package length	7.5 m 24.6 ft	7.5 m 24.6 ft	7.5 m 24.6 ft

SCOPE OF DELIVERY

Including:

- 1 Enclosed orbital weld head OW 38S, OW 76S or OW 115S
- 1 Durable storage and shipping case
- 1 Tool set
- 1 Operating instructions and spare parts list

Suitable accessories (available option):

- Clamping inserts, small and wide
- Plastic case for clamping inserts
- Cavity inserts for moldings
- Inserts for elbow welding
- T-piece clamping shells
- Electrode adapters
- Table mounts
- ESG tungsten grinders
- ORBmax residual oxygen meter
- ORBIPURGE forming set
- Hose package extensions
- Inspection set
- WS2 tungsten electrodes

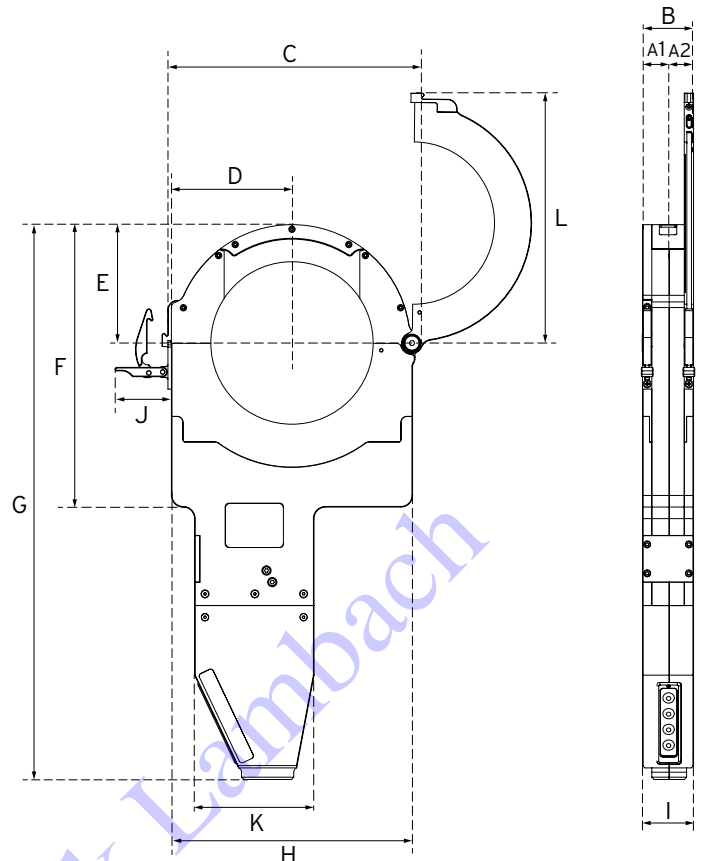

ORBIWELD 38S	DIMENSION		ELECTRODE INTERVAL		ORBIWELD 76S	DIMENSION		ELECTRODE INTERVAL		ORBIWELD 115S	DIMENSION		ELECTRODE INTERVAL			
	[MM]	[INCH]	CLAMPING INSERT [2 PAIRS]	[MM]		[INCH]	CLAMPING INSERT [2 PAIRS]	[MM]	[INCH]		CLAMPING INSERT TYPE "S" [2 PAIRS]	CLAMPING INSERT TYPE "W" [2 PAIRS]	[MM]	[INCH]	[MM]	[INCH]
Dimension "A1"	17.00	0.669	17.50	0.689	Dimension "A1"	19.00	0.748	21.00	0.827	Dimension "A1"	22.75	0.896	25.75	1.014	45.75	1.801
Dimension "A2"	17.00	0.669	17.50	0.689	Dimension "A2"	19.00	0.748	21.00	0.827	Dimension "A2"	21.25	0.837	24.25	0.955	44.25	1.742
Dimension "B"	34.00	1.339	35.00	1.378	Dimension "B"	38.00	1.496	42.00	1.654	Dimension "B"	44.00	1.732	50.00	1.969	90.00	3.543
Dimension "C"	112.00	4.409			Dimension "C"	159.00	6.260			Dimension "C"	220.00	8.661				
Dimension "D"	47.50	1.870			Dimension "D"	67.50	2.657			Dimension "D"	104.00	4.094				
Dimension "E"	47.00	1.850			Dimension "E"	66.00	2.598			Dimension "E"	102.00	4.016				
Dimension "F"	144.00	5.669			Dimension "F"	187.00	7.362			Dimension "F"	244.00	9.606				
Dimension "G"	357.00	14.055			Dimension "G"	400.00	15.748			Dimension "G"	480.00	18.898				
Dimension "H"	95.00	3.740			Dimension "H"	135.00	5.315			Dimension "H"	208.00	8.189				
Dimension "I"	34.00	1.339			Dimension "I"	34.00	1.339			Dimension "I"	44.00	1.732				
Dimension "J"	55.00	2.165			Dimension "J"	55.00	2.165			Dimension "J"	55.00	2.165				
Dimension "K"	71.00	2.795			Dimension "K"	71.00	2.795			Dimension "K"	102.00	4.016				
Dimension "L"	110.00	4.331			Dimension "L"	153.00	6.024			Dimension "L"	216.00	8.504				



ORBIWELD 38S



ORBIWELD 76S

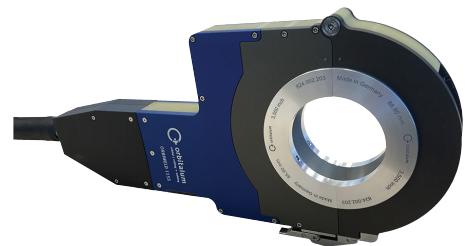

ORBIWELD 115S